



ECON® Butterfly valve Type: 6431 Ductile cast iron/Stainless steel EC1935 Squeeze handle Lug type

Characteristics

Type: 6431
Norm: EN [DIN]
Valve design: Centric
Housing material: Ductile cast iron
Material quality: EN-JS1030
Surface protection: Epoxy coating [external]
Connection: Lug type
Standard connection: EN [DIN]
Face to Face norm: EN 558, Series 20
Operation: Squeeze handle
Top flange standard: ISO 5211 Direct Mount
Housing lining: Replaceable
Disk material: Stainless steel
Quality class disc: 1.4408
Actuator material: EN-JS1030

Application

- Industrial applications such as (drinking) water, hydrocarbons and slightly corrosive fluids and gases.
- Food applications for which the EC1935 standard is required.
- Recommended in: Chemical, Food & Beverages

Technical Information

- Fitted with replaceable lining.
- One-piece spindle in an anti-blowout design.
- With direct mount top-flange in accordance with ISO 5211.
- Three-point spindle bearing for excellent life cycle management.
- Grooved connection between spindle and valve disc.
- The body is provided with a two-layer epoxy coating with the upper layer in RAL 5015.
- Suitable as an end fitting up to the maximum pressure class for DN 50-DN 200.
- Equipped with lever.
- Dimensions in DN 50-DN 200 [2" to 8"].
- Flange connection pressure class for DN 50–DN 200 [2" to 8"]: PN 10, PN 16.
- Maximum medium temperature depends on the lining: EPDM EC1935 -10 to +140°C.

Construction

- Socket outlet type.
- Design according to EN 593, API 609 and ASME B16.34.
- The pressure class of the standard design is PN 16 for DN 50 to DN 200 and PN 10 for DN 250 to DN 600.
- Construction length according to EN 558 series 20, ISO 5752 series 20 and API 609 category A.
- Suitable for mounting with flanges according to EN 1092-2.
- Bi-directional bubble-tight sealing according to EN 12266 rate A and API 598.

Approval

- Food approval according to EC1935 and FDA.

Options

- Available as a wafer type (series 63).
- Socket outlet according to class 150.
- Equipped with worm gearbox and pneumatic, electric or hydraulic actuators.
- Position feedback for manually actuated or automated valves.

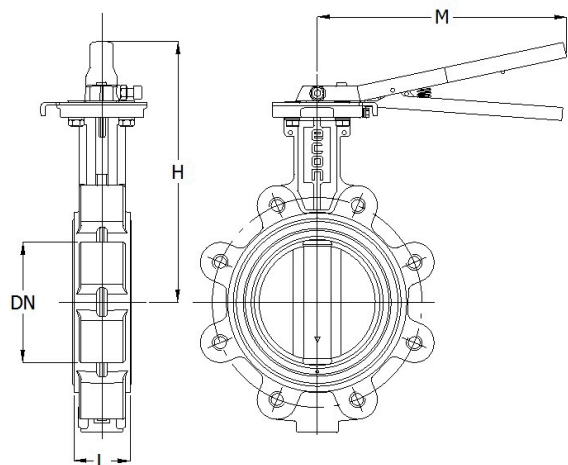

Size table:

DN	H mm	L mm	M mm	Weight kg
DN50	195	43	207	3.2
DN65	207	46	207	4.2
DN80	225	46	248	5.2
DN100	244	52	248	6.1
DN125	260	56	248	8.4
DN150	273	56	265	10.3

Temperature and pressure range					
Size	Liner	Pressure rating	Temperature range	Maximum operating pressure	
DN50-DN200	EPDM	PN16	EPDM -10°/+140°C	16	[bar]

Nominal inner diameter	Pressure rating	Pressure rating flange	Face to Face length mm	Material liner	Spindle material	Quality class spindle	Minimum medium temperature (continuous) °C	Maximum medium temperature (continuous) °C	Maximum pressure difference as end valve bar	Article
DN50	PN16	PN10/16	43	EPDM-EC1935	Stainless steel	1.4006	-10	140	16	EC6431E0050-DDAA
DN65	PN16	PN10/16	46	EPDM-EC1935	Stainless steel	1.4006	-10	140	16	EC6431E0065-DDAA
DN80	PN16	PN10/16	46	EPDM-EC1935	Stainless steel	1.4006	-10	140	16	EC6431E0080-DDAA
DN100	PN16	PN10	52	EPDM-EC1935	Stainless steel	1.4006	-10	140	16	EC6431E0100-DDAA
DN125	PN16	PN10	56	EPDM-EC1935	Stainless steel	1.4006	-10	140	16	EC6431E0125-DDAA
DN150	PN16	PN10/16	56	EPDM-EC1935	Stainless steel	1.4006	-10	140	16	EC6431E0150-DDAA

Disclaimer: The content of this document has been composed with the utmost care. However, it is possible that certain information changes over time, becomes inaccurate or incomplete. ERIKS does not guarantee that the information provided on this document is up to date, accurate and complete; the information provided is not intended to be advice. ERIKS shall never be liable for damage resulting from the use of the information provided.