



GUTH VENTILE High-pressure butterfly Valve Series: 4310 Stainless steel AISI 316L/EPDM Lever Intermediate flange Butt weld NEN EN10357 serie A



Characteristics

Series: 4310

Norm: EN (DIN)

Valve design: Centric

Housing material: Stainless steel

Abbreviation name of material: AISI 316L

Material quality: 1.4404

Internal roughness value: Ra ≤ 0.8 µm electro polished

Connection: Butt weld

Standard connection: EN 10357 series A

Operation: Handle

Housing lining: Replaceable

Disk material: AISI 316L

Quality class disc: 1.4404

Ambient temperature: 4 / 45 °C

Approval

- EC1935/2004 certification towards the seat.
- FDA admission towards the seat.

Options

- Pneumatic actuation.
- Extended control and signalling capabilities.
- Construction in stainless steel AISI 304L (1.4307).
- Sealing in silicone, HNBR or FPM.
- Connection with Tri-clamp according to DIN 32676.
- Weld connection according to EN10357 Series A (DIN 11850 Series 2).
- Threaded connection according to DIN 11851 or DIN 11864.
- Three-way design through T-piece connection.
- 3.1 Certificate.

Application

- Food products.
- Dairy.
- Milk.
- Beer.
- CIP.
- Fruit juice.
- Water.
- Sauces.
- Oils.
- Recommended in: Food & Beverages, Food primary processes (contact with food)

Technical Information

- Operation open/closed.
- Sterilisation temperature 140 °C (SIP 30 min.).

Construction

- Two-piece body and one-piece valve/spindle.
- Centric valve design.
- Equipped with bearing bushings.

Disclaimer: The content of this document has been composed with the utmost care. However, it is possible that certain information changes over time, becomes inaccurate or incomplete. ERIKS does not guarantee that the information provided on this document is up to date, accurate and complete; the information provided is not intended to be advice. ERIKS shall never be liable for damage resulting from the use of the information provided.

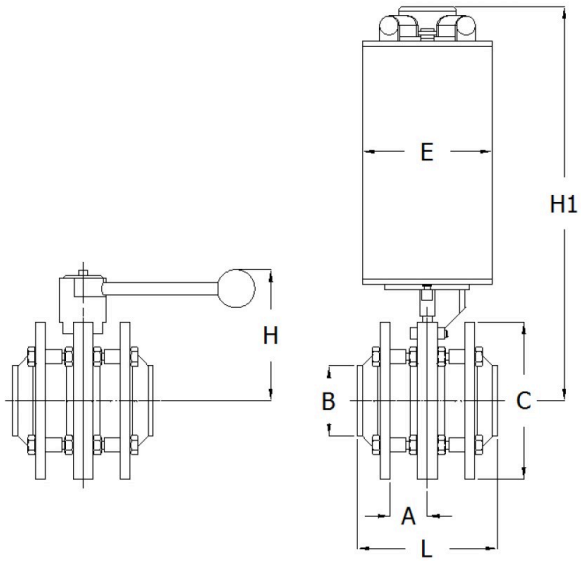

Size table:

DN	A mm	B mm	C mm	H mm	L mm
DN100	74	104	104	134	148
DN25	51	29	104	88	106
DN32	53	35	104	88	106
DN40	54	41	104	94	108
DN50	54	53	104	101	108
DN65	54	70	104	110	108
DN80	72	85	104	122	144

Nominal inner diameter	External tube diameter of connection	Wall thickness, connection	Pressure rating	Face to Face length	Material liner	Minimum medium temperature (continuous)	Maximum medium temperature (continuous)	Maximum pressure difference as end valve	Article
	mm	mm		mm		°C	°C	bar	
DN100	104	2	PN40	148	EPDM	0	120	10	14671815
DN100	29	1.5	PN40	106	EPDM	0	120	33	14671809
DN32	35	1.5	PN40	106	EPDM	0	120	33	14671810
DN40	41	1.5	PN40	108	EPDM	0	120	33	14671811
DN50	53	1.5	PN40	108	EPDM	0	120	33	14671812
DN65	70	2	PN40	108	EPDM	0	120	33	14671813
DN80	85	2	PN40	144	EPDM	0	120	10	14671814

Disclaimer: The content of this document has been composed with the utmost care. However, it is possible that certain information changes over time, becomes inaccurate or incomplete. ERIKS does not guarantee that the information provided on this document is up to date, accurate and complete; the information provided is not intended to be advice. ERIKS shall never be liable for damage resulting from the use of the information provided.