



LVF Check valve Type: 1730 Steel Internal thread (NPT) Class 800

Forged steel check valve, piston type, with bolted cover and NPT thread ends, Class 800.

Characteristics

- Type:** 1730
- Norm:** ASME
- Construction type:** Straight
- Housing material:** Steel
- Material quality:** ASTM A105N
- Surface protection:** Phosphated
- Connection:** Internal thread (NPT)
- Standard thread connection:** ASME B1.20.1
- With spring:** Yes
- Maximum medium temperature (continuous):** 426 °C
- Maximum pressure difference at 20 °C:** 136 bar

Application

- Refineries and (petro-) chemical procesinstallations.
- Oil & gas industry.
- Steam and oil.
- Neutral liquids and gases.
- Recommended in: Chemical, Petrochemical and Refining

Technical Information

- Design: API602, ASME B16.34.
- Testing: API598.
- Emission standard: API 624, based on globe valve test.
- NACE MR01-75, MR01-03.

Options

- Available in stainless steel; type 1720.
- Available with socket weld connections; type 1732.
- Available in Class 1500.
- Available in other materials.
- Available for cryogenic or high temperature applications.

Size table:

DN	H	L	Weight
	mm	mm	kg
3/4" [20]	55	90	1.8
1.1/2" [40]	105	155	5.5

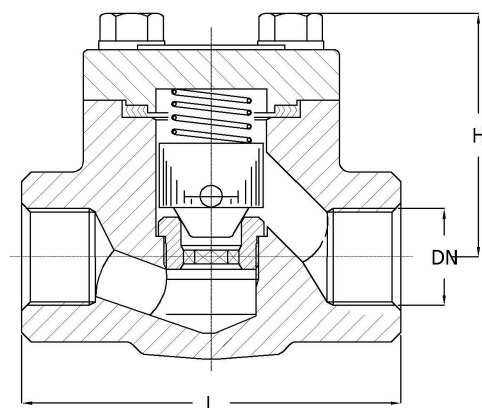

Pressure and temperature table

-29/38	50	100	150	200	250	300	350	400	425	450	500	538	[°C]
--------	----	-----	-----	-----	-----	-----	-----	-----	-----	-----	-----	-----	------

Disclaimer: The content of this document has been composed with the utmost care. However, it is possible that certain information changes over time, becomes inaccurate or incomplete. ERIKS does not guarantee that the information provided on this document is up to date, accurate and complete; the information provided is not intended to be advice. ERIKS shall never be liable for damage resulting from the use of the information provided.

Non-return Valves | Non-return Valves with Threaded Connection

Pressure and temperature table													
136.2	133.7	124.3	120.2	116.8	106.2	103.2	100.2	92.6	76.7	61.3	31.4	15.7	[bar]
ASTM A105N is not recommended for long-term use above 425 °C.													
Check the above values and any additional comments with API602.													

Nominal inner diameter	Pressure rating	Face to Face length	Valve shape	Sealing	Material disc	Material cover	Material cover gasket	Spring material	Minimum medium temperature (continuous)	Article
		mm							°C	
3/4" [20]	Class 800	90	Flap	Trim 8	ASTM A479 410	ASTM A105N	Stainless steel 316 SW Graphite filled	ASTM A479 316	-29	13614949
1.1/2" [40]	Class 800	155	Flap	Trim 8	ASTM A479 410	ASTM A105N	Stainless steel 316 SW Graphite filled	ASTM A479 316	-29	13614951

Disclaimer: The content of this document has been composed with the utmost care. However, it is possible that certain information changes over time, becomes inaccurate or incomplete. ERIKS does not guarantee that the information provided on this document is up to date, accurate and complete; the information provided is not intended to be advice. ERIKS shall never be liable for damage resulting from the use of the information provided.